



put an  
elevator  
in your plans

**Whatever your needs...**

**American Crescent/Matot is here**

*two family-owned companies  
one powerful alliance  
a world of quality elevators*

With over 135 years of combined service, American Crescent/Matot has created the finest residential elevators available in the market. The combination of our expertise and experience provides improved lead times, excellent cab selections and impeccable service. In fact, we're so proud of our century of craftsmanship and state-of-the-art engineering that we back every product we build with AC/Matot's promise of quality. Think of it as a family tradition.

Here are just a few of the reasons why AC/Matot elevators are showing up in more households than ever before.

- Reduces stair climbing in today's taller, multi-story homes
- Allows those who have difficulty climbing stairs to continue living comfortably in their own homes
- Adds significantly to a home or condo's resale value

Practicality aside, an AC/Matot elevator is a tasteful touch of luxury that makes a big impression.

A quality product is only as good as the service it comes with. That's why we are absolutely committed to solving our customers' evolving needs. We're constantly building our distribution network in order to guarantee installation excellence and local on-site support. Architects, contractors, and distributors know from experience that AC/Matot products are easy to install in space-conscious, new construction or tight retrofitting applications. They appreciate the time-tested quality, plus the variety of available drive mechanisms in the AC/Matot line. If our partners are pleased with our work, just imagine how you'll feel when you step into your very own AC/Matot elevator.

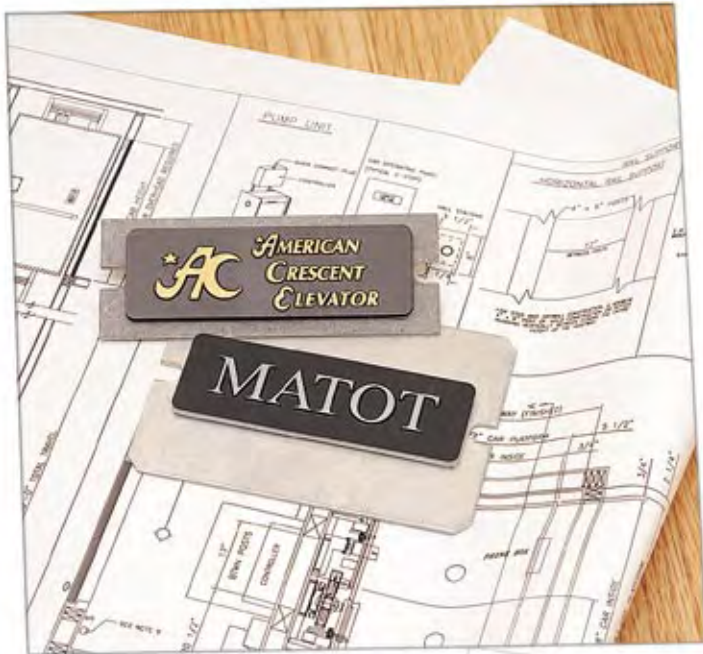

Whatever your lifestyle, an AC/Matot elevator is just the right fit.

Whether you're building your dream house, or already living in it, we're ready to assist you immediately. We have everything you need to get started, with a wide variety of distinctive elevators, cab styles and options. If you're not quite ready, we're happy to help you plan everything in advance and let you defer payment and installation until it's convenient.

So learn what an AC/Matot elevator can do for you.

Because we understand—it's more than just a matter of convenience. It's a matter of lifestyle.

Call today. It's just a few simple steps to no more stairs.

1. *choose an elevator*
2. *select a cab*
3. *personalize it*
4. *work it into your plans*

Whatever your expectations...  
the highest quality elevators available

## Elite® Elevator

As the highest-quality winding drum elevator available, the AC/Matot Elite Elevator will satisfy all your expectations. When you select the Elite, you receive increased mobility and added convenience, all in a smooth, quality ride.

The Elite is designed to expand your options, with the machine installation either adjacent to the elevator shaft, or our new, space-saving overhead drive system. **Plus, the unique, battery-operated emergency lowering system comes as a standard feature.** All in all, the Elite is an affordable investment and the perfect solution for your home.

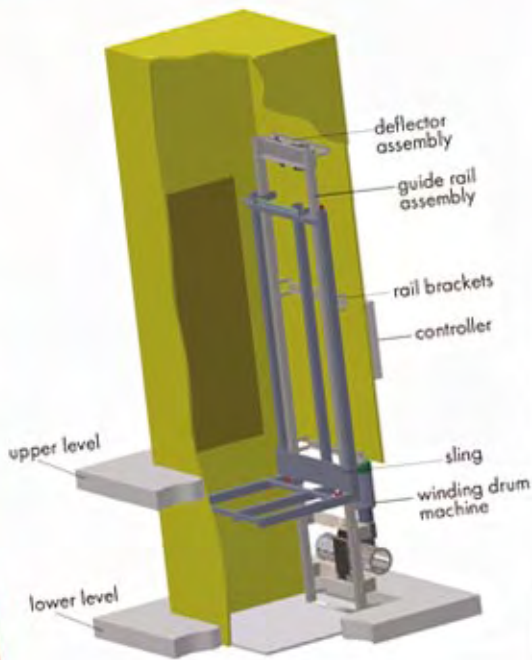

winding drum drive

### Elite Standard Features:

- Winding drum drive
- 750 lbs. Lift capacity
- 30 F.P.M. nominal operating speed
- Programmable solid state control
- Sierra cab "A" style
- Cab size: 36"w x 48"d x 80"h clear inside
- Prewired car
- Battery operated "Power Down" emergency lowering and lighting
- 2 stops w/ 10 ft. of travel
- Compact machine design saves floor space (only 18" required)
- Deflector sheaves and machine mount directly to the rails with vibration isolating elastomer mounts
- Loads are transferred to the pit floor through the guide rails

## Regal® Elevator

The Regal offers the highest quality residential lift system available. It utilizes the same hydraulic drive technology built into commercial low-rise elevator systems. AC/Matot's Regal Elevator provides convenience for homeowners with a preference for advanced technology.

The flexibility of the hydraulic drive system allows you to locate the machine room adjacent to the shaftway or in a remote location at any floor. The Regal works with many architectural adaptations while providing easy access and operation.

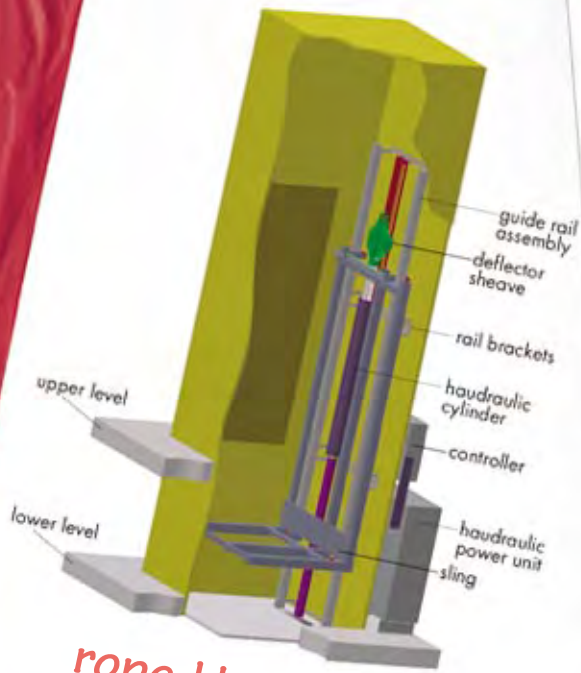

*roped hydraulic drive*

### **Regal Standard Features:**

- Roped hydraulic drive
- 750 lbs. lift capacity
- 40 F.P.M. nominal operating speed
- Two speed valve
- Self leveling
- Programmable solid state control
- Sierra cab "A" style
- Cab size: 36"w x 48"d x 80"h clear inside
- Prewired car
- Battery operated "Power Down" emergency lowering and lighting
- 2 stops w/ 10 ft. of travel
- Separate machine room with location flexibility

Whatever your style...  
a cab for any individual



**executive cab**

shown with optional bronze bostwick gate

**Executive Cab Standard Features:**

- 7/8" hardwood oak raised panels w/clear coat finish
- Bronze handrail
- Two recessed ceiling lights
- Bronze pushbutton faceplates and cab trim
- LiteView car gate w/ 3 clear center panels
- Bronze recessed phone box
- Hardwood floor

Optional panel materials: Hardwood—cherry, walnut, mahogany, maple, or ash.



**sierra cab**

**Sierra Cab Standard Features:**

- 3/4" melamine particle board cab panels
- Solid oak handrail
- Two recessed ceiling lights
- Stainless steel pushbutton faceplates and cab trim
- LiteView car gate w/ 3 clear center panels
- Convenient wall-mounted telephone
- Prewired car
- Unfinished floor

Standard panel materials: Melamine— oak, walnut, mahogany, or white. Unfinished veneer— oak or birch.

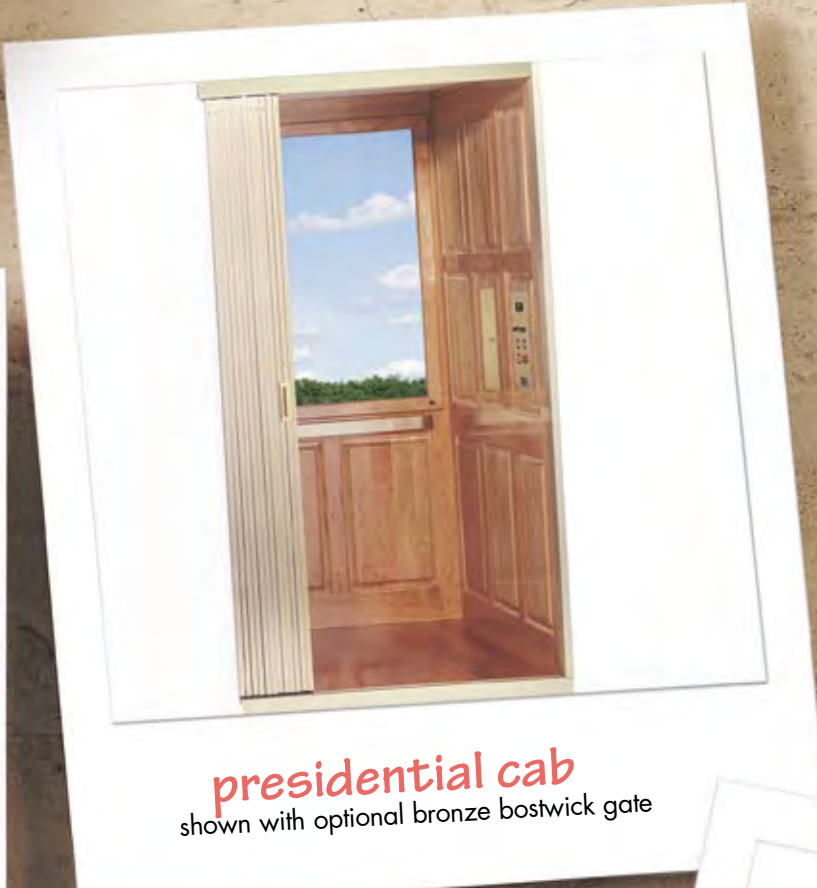

**presidential cab**  
shown with optional bronze bostwick gate

- Presidential Cab Standard Features:**
- 7/8" hardwood oak raised panels w/clear coat finish
  - Bronze handrail
  - Two recessed ceiling lights
  - Bronze pushbutton faceplates & cab trim
  - LiteView car gate w/ 3 clear center panels
  - Bronze recessed phone box
  - Hardwood floor
  - 1/4" safety glass window positioned in rear wall above the handrail

Optional panel materials: Hardwood—cherry, walnut, mahogany, maple, or ash.

- Plantation Cab Standard Features:**
- 3/4" MDF walls with raised panels painted glossy white
  - Bronze handrail
  - Two recessed ceiling lights
  - Bronze pushbutton faceplates and cab trim
  - LiteView car gate w/ 3 clear center panels
  - Bronze recessed phone box
  - Hardwood floor



**plantation cab**  
shown with stainless steel package

Whatever your style...  
a cab for any individual

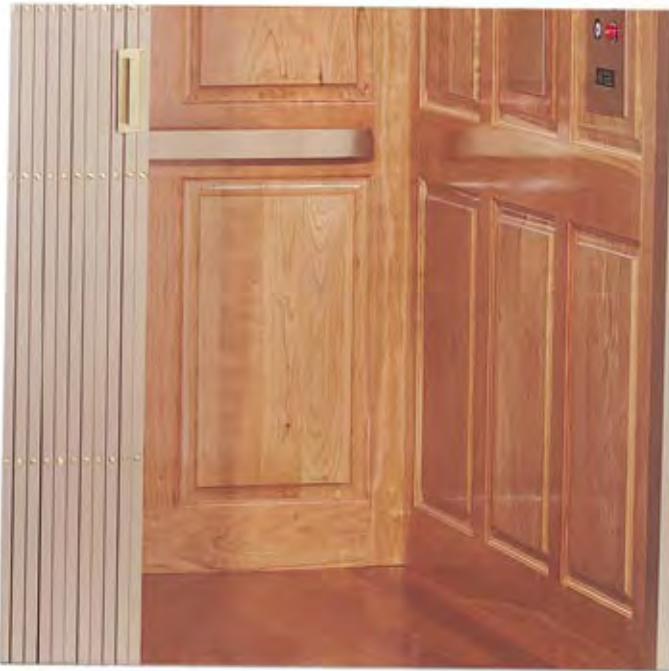

### *executive cab*

shown with optional bronze bostwick gate

#### **Executive Cab Standard Features:**

- 7/8" hardwood oak raised panels w/clear coat finish
- Bronze handrail
- Two recessed ceiling lights
- Bronze pushbutton faceplates and cab trim
- LiteView car gate w/ 3 clear center panels
- Bronze recessed phone box
- Hardwood floor

Optional panel materials: Hardwood—cherry, walnut, mahogany, maple, or ash.



### *sierra cab*

#### **Sierra Cab Standard Features:**

- 3/4" melamine particle board cab panels
- Solid oak handrail
- Two recessed ceiling lights
- Stainless steel pushbutton faceplates and cab trim
- LiteView car gate w/ 3 clear center panels
- Convenient wall-mounted telephone
- Prewired car
- Unfinished floor

Standard panel materials: Melamine—oak, walnut, mahogany, or white. Unfinished veneer—oak or birch.



**presidential cab**  
shown with optional bronze bostwick gate

**Presidential Cab Standard Features:**

- 7/8" hardwood oak raised panels w/clear coat finish
- Bronze handrail
- Two recessed ceiling lights
- Bronze pushbutton faceplates & cab trim
- LiteView car gate w/ 3 clear center panels
- Bronze recessed phone box
- Hardwood floor
- 1/4" safety glass window positioned in rear wall above the handrail

Optional panel materials: Hardwood—cherry, walnut, mahogany, maple, or ash.

**Plantation Cab Standard Features:**

- 3/4" MDF walls with raised panels painted glossy white
- Bronze handrail
- Two recessed ceiling lights
- Bronze pushbutton faceplates and cab trim
- LiteView car gate w/ 3 clear center panels
- Bronze recessed phone box
- Hardwood floor



**plantation cab**  
shown with stainless steel package

# Whatever your tastes... options to compliment your personality

AC/Matot residential elevators are designed with an outstanding array of standard features. But you also have the opportunity to create a unique custom elevator by combining those features and optional accessories that will add convenience and personalize your cab interior.

- Wide array of panels and trim (actual color or pattern may vary from this representation- contact us for special color laminates)
- Custom cab height-maximum 95" (requires additional overhead clearance)
- Custom platform-larger than 36"x48"x80" (check with local code compliance; contact us for increased hoistway and clearance specifications)
- Power operation for LiteView folding cab gate(s)
- Additional recessed ceiling lights (2 are standard)



telephone cabinet

## Melamine laminates



## Unfinished hardwood veneers



## Trim

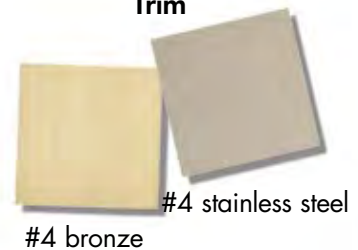

## Raised panels



## panels and trim



power door operator



## gates

bostwick gate and LiteView folding gate

### Additional Cab Options

- #4 satin finish bronze or stainless steel recessed telephone cabinet with door (wall-mounted is standard)
- Raised ceiling panels
- Glass inserts
- #4 satin bronze package (includes fixtures, handrail & cab trim)

### Gates

- LiteView folding gate w/ 3 clear center panels (standard)
- All clear LiteView folding gate
- #4 satin finish bronze bostwick gate
- #4 satin finish stainless steel bostwick gate

### Handrails

- Solid oak
- #4 satin bronze
- #4 satin stainless steel

### Other Options

- 1000 lb capacity—Regal only (requires 12" pit)
- Power operation for swing hoistway door(s) (hoistway doors not supplied)
- Automatic cab lighting timer (turns car lights on when in use)
- 3, 4, and 5 stop packages
- V.V.V.F. drive—Elite only



## handrails



## operating controls

# Whatever your home... A perfect fit for your plans

## hoistway plans

Use these charts to assist you in determining the approximate dimensions for your residential elevator shaftway. Each elevator has a required machine location. Consult your local AC/Matot distributor for further details and code restrictions.

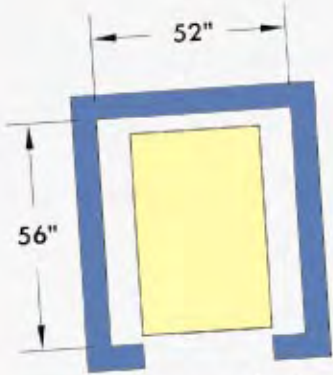

In-line style A

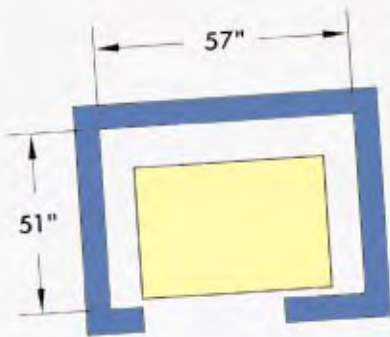

In-line style B

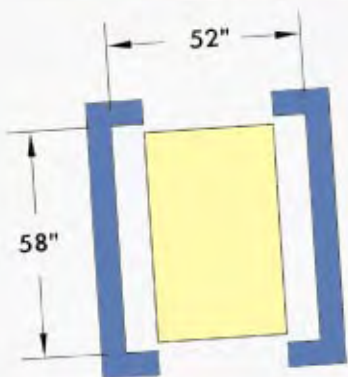

Opposite style C

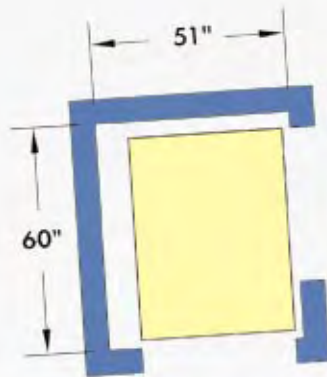

Adjacent style D

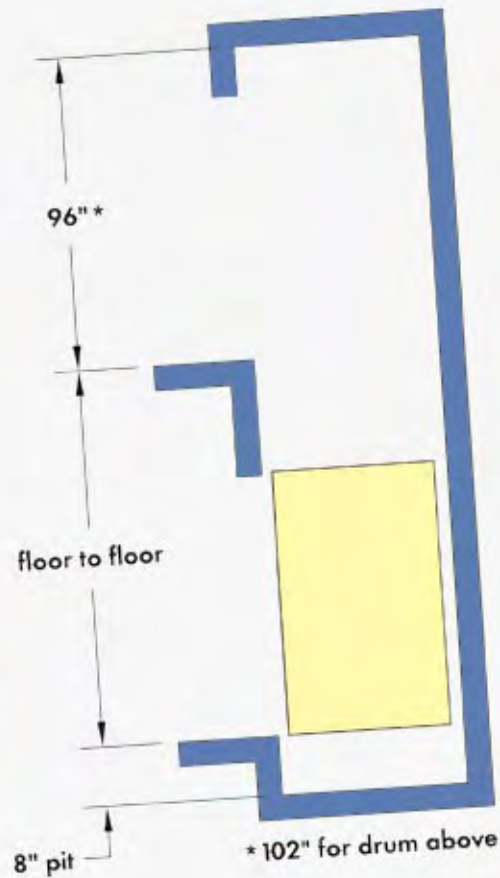

Hoistway dimensions shown for 36" w x 48" d x 80" h cabs. Contact your AC/Matot sales representative for optional cab sizes and clearance limitations. Dimensions are subject to change without notice.

## specifications

### 2.01 Manufacturer.

American Crescent/Matot,  
Picayune, MS. or Bellwood, IL.

### 2.02 Product Type.

- A. Model shall be the  Elite winding drum drive with two 8 inch diameter drums, upper and lower final limit switches, 8 ft clear overhead required on drum below and 8 ft 6 in required on drum overhead, 8 inch deep pit, nominal travel speed of 30 F.P.M., 45 ft maximum lifting height or  Regal 1:2 roped hydraulic, tape selector, 8 ft clear overhead required, 8 inch deep pit, nominal travel speed of 40 F.P.M., 50 ft maximum lifting height.
- B. Car to be 36 inches wide by 48 inches deep with a minimum inside clear height of 6'-8". Lifting capacity to be 750 pounds. Elevator serves \_\_\_ stops, and \_\_\_ openings, located on:  same,  opposite,  adjacent side(s) of the hoistway and travels a total distance of \_\_\_ ft \_\_\_ in.

### 2.03 Fabrication.

- A. CAB:  Sierra,  Executive,  Plantation, or  Presidential
- B. LIGHTING: Lighting will consist of two recessed ceiling lights operated on a separate 110 volt circuit.
- C. CAR GATE: Each open side of cab shall be equipped with a folding car door with three clear acrylic center panels.
- D. DOOR INTERLOCKS: A hoistway door interlock shall be furnished for each

hoistway entrance. Interlock shall prevent operation unless doors are closed and prevent opening of door when car is not at that landing.

- E. CONTROLLER: Controller shall be programmable, solid state, wall mounted type with lockable door, located in the machine room. Auto call, single floor register operation shall be provided.
- F. OPERATION: Operation shall be automatic. A call station shall be furnished for each entrance. A push-button station in the car shall have one button for each level served. Car station shall also contain an emergency stop switch, alarm button, and light switch. Alarm bell shall be furnished on top of car.
- G. GUIDE RAILS: Shall be two steel members with smooth splices, located on one side of the Hoistway to accurately guide the car, secured to the hoistway wall by suitable brackets and hardware.
- H. CARRIAGE: Carriage shall be attached to the car platform on the guide rail side of the car. Instantaneous broken cable device shall be provided on the carriage.
- I. CABLES: Two 3/8" x 8 x 19 steel cables.
- J. ELECTRIC SUPPLY: Shall be 220 volt, single phase, 30 amps, 60 hertz.

Contact your AC/Matot sales representative or visit our web sites for complete specifications.

Specifications and dimensions subject to change without notice.



call now and  
let us take you  
to the top!

[www.matot.com](http://www.matot.com)

Matot Inc.  
2501 Van Buren  
Bellwood, Il 60104-2459  
(708) 547-1888 Main  
(708) 547-1608 Fax  
(800) 369-1070 Sales  
email: sales@matot.com

American Crescent Elevator Mfg., Corp.  
310 Stephens Street  
Picayune, MS 39466  
(601) 798-9392 Main  
(601) 798-9444 Fax  
(800) 748-9711 Sales  
email: sales@americancrescent.com

[www.americancrescent.com](http://www.americancrescent.com)

